

STRAIGHT PLUG CRIMP TYPE

R214.075.000

CABLE 2.6/75 S

Series : SMZ

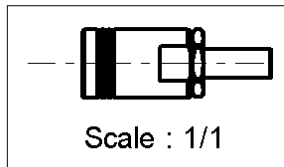
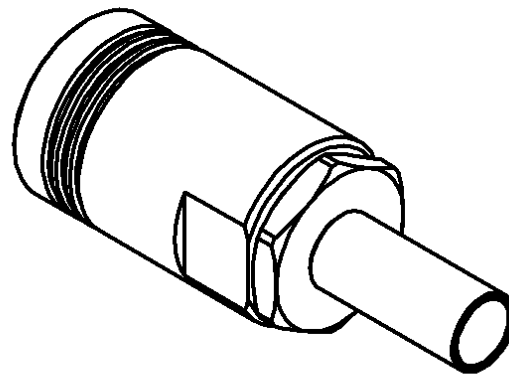
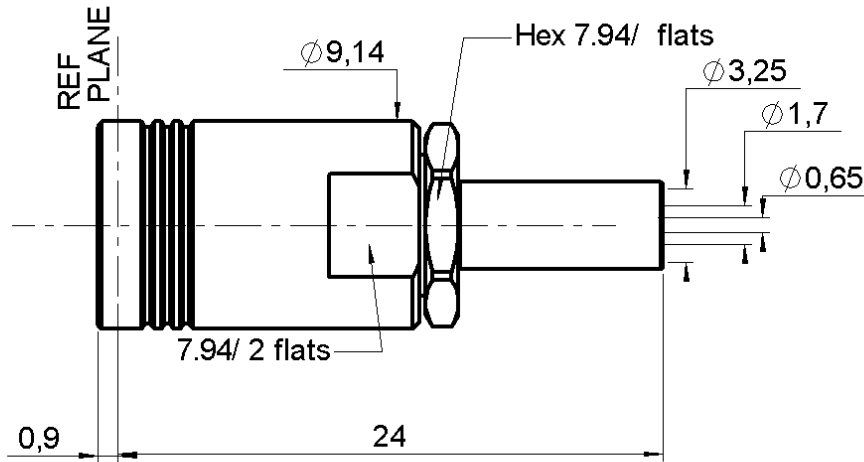

All dimensions are in mm.



COMPONENTS	MATERIALS	PLATINGS (µm)
BODY	BRASS	GOLD 0.2 OVER NICKEL 2
CENTER CONTACT	BERYLLIUM COPPER	GOLD 1.3 OVER NICKEL 2.54 OVER COPPER
OUTER CONTACT	BERYLLIUM COPPER	3
INSULATOR	PTFE	GOLD 0.5 OVER NICKEL 2
GASKET	-	
OTHERS PARTS	BRASS	
-	-	GOLD 0.2 OVER NICKEL 2
-	-	-

Issue : 0045 B

In the effort to improve our products, we reserve the right to make changes judged to be necessary.



STRAIGHT PLUG CRIMP TYPE

R214.075.000

CABLE 2.6/75 S

Series : SMZ

PACKAGING

Standard	Unit	Other
100	'W' option	Contact us

SPECIFICATION

CABLE ASSEMBLY

ELECTRICAL CHARACTERISTICS

Stripping	a	b	c	d	e	f
mm	2.25	6.90	16.2	0.00	14.0	0.00

Impedance		75	Ω
Frequency		0-2.4	GHz
VSWR	1.20 +	0.000	x F(GHz) Maxi
Insertion loss		0.12	\sqrt{F} (GHz) dB Maxi
RF leakage	- (60	- F(GHz)) dB mini
Voltage rating		250	Veff Maxi
Dielectric withstanding voltage		750	Veff mini
Insulation resistance		500	M Ω mini

Assembly instruction :

Recommended cable(s)
RG 179
RG 187

Cable retention

- pull off **120** N mini
- torque **NA** N.cm

MECHANICAL CHARACTERISTICS

TOOLING

Center contact retention			
Axial force – Mating end		10	N mini
Axial force – Opposite end		10	N mini
Torque		NA	N.cm mini

Part Number	Description	Hexagon
.	.	.
R282.211.000	CRIMPING TOOL	3.25
R282.293.000	CRIMPING TOOL	-
R282.235.003	CRIMPING DIES	3.25

Recommended torque			
Mating		NA	N.cm
Panel nut		NA	N.cm
Clamp nut		100	N.cm
A/F clamp nut		7.940	mm

OTHERS CHARACTERISTICS

Mating life		250	Cycles mini
Weight		0.000	g

ENVIRONMENTAL

Operating temperature		-55/+155	$^{\circ}$ C
Hermetic seal		NA	Atm.cm3/s
Panel leakage		NA	

Issue : 0045 B

In the effort to improve our products, we reserve the right to make changes judged to be necessary.



STRAIGHT PLUG CRIMP TYPE

R214.075.000

CABLE 2.6/75 S

Series : SMZ

COMPONENTS

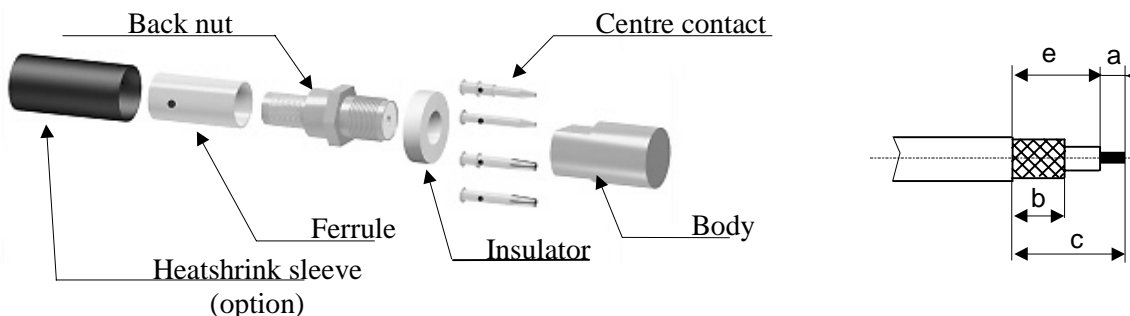

1

Slide the heatshrink sleeve onto the cable (Option).
Slide the ferrule onto the cable.
Position the ferrule's hole at the front if soldering.
Position the ferrule's hole at the back if crimping.
Strip the cable.

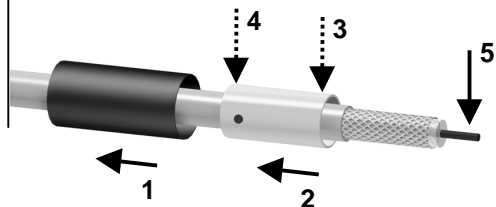

4

Slide the centre contact on until it bottoms against the insulator back nut.
Solder or crimp the contact (see connector TDS).

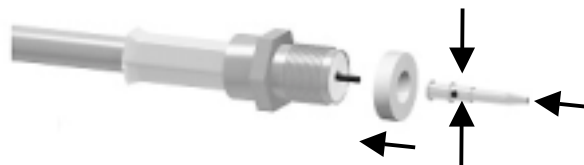

2

Fan the braid.
Slide the cable into the back nut.

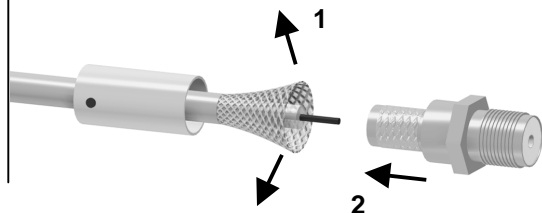

5

Screw the back nut into the connector body with the adapted wrench.
Recommended coupling torque 63 to 70 N cm.

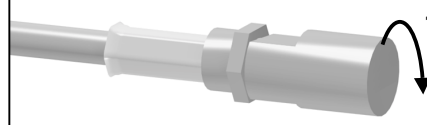

3

Slide the ferrule over the braid.
Crimp the ferrule with crimping tool (see connector TDS).

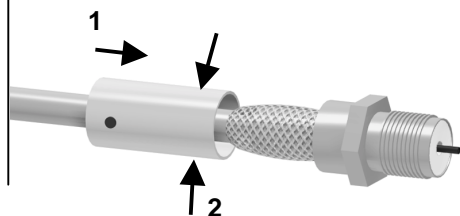

6

Slide the sleeve over the ferrule and heatshrink it in place (option).

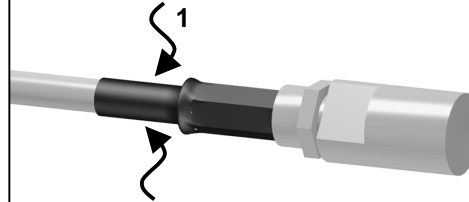

Issue : 0045 B

In the effort to improve our products, we reserve the right to make changes judged to be necessary.

